



**OPERATION & INSTRUCTION MANUAL
PORTABLE GRINDING/POLISHING & ELECTROLYTIC ETCHING**

MOBIPREP



EC Declaration of Conformity

- Manufacturer** : Metkon Instruments Inc.
- Address** : Demirtas Dumlupinar Organize Sanayi Bolgesi
Ali Osman Sonmez Cd. No: 14 Bursa / TURKEY
- Model No** : MOBIPREP

Herewith declares that;

Portable Grinding/Polishing & Electrolytic Etching Machine

Confirms that it complies with the rules, in particular the protection requirements, which in the European Community Directive on the approximation of the laws relating to electromagnetic compatibility (89/336/EEC), the Directive amending the CE marking (93/68/EEC) and the Act are set out on the electromagnetic compatibility of equipment as of 18.09.1998.

This declaration applies to all identical copies of the product.

To assess the product with regard to electromagnetic compatibility, the following relevant harmonized European standards have been applied, the reference numbers of which have been published in the Official Journal of the European Communities.

.....
Date: 2017

Index

DESCRIPTION	4
Design	4
Technical Data	5
Warranty	6
Safety Precautions	6
INSTALLATION & SET UP	7
Unpacking & Checking Contents of Package	7
Installation and Set-Up	7
Electrical Installation	7
OPERATION	8
Charging the Battery	8
Connection of the Attachments to the Brushless DC Motor	8
Reduction Gear (Reducer) Connection	8
90° and 45° Angle Attachment Connection	9
Changing the Grinding and Polishing Carriers on Angle Attachment	9
Straight Quick Release Piece Connection (Optional)	9
Changing the Grinding and Polishing Carriers on Straight Quick Release Piece (Optional)	9
Grinding and Polishing Operation	10
Etching (Optional)	10
Recommended Electrolytes	10
Replica	10
SERVICE AND MAINTENANCE	11
Maintenance	11
Troubleshooting	11
ACCESSORIES AND CONSUMABLES	12
Accessories	12
Consumables	12
TECHNICAL DOCUMENTATION	14
Customer Service	14

DESCRIPTION

Design

MOBIPREP is a battery powered portable Grinder / Polisher and etcher designed for metallographic sample preparation in field or in laboratory. MOBIPREP contains maintenance-free batteries to work without stationary mains, consists of a control unit and a precision hand-guided grinding-polishing device with high performance micro motor. MOBIPREP's hand-guided device can be used with either 45° or 90° angle or straight grinding-polishing pieces.

The switch for ON/OFF is on the hand-guide and provides a click sensation with a confirmation tone from the control unit when the switch is operated. All accessories are supplied with a hardcase protection and carrying bag where you have sufficient space to place your consumables. With the etching pen, MOBIPREP can be used for electrolytic etching. Thus working in field with alloyed steels is possible which can be etched by weak electrolytes instead of strong acids.



Technical Data

Model Order No	MOBIPREP 90 01
Voltages	36V or 100-240V / 50-60 Hz.
Speed	0 – 25.000 rpm
2 LED Indicator	On / Low Battery
Operation Modes	E – Etching-1 (E1)
	EP – Etching-2 or Polishing-1 (E2 or P1)
	EPG – Etching-3 or Polishing-2 or Grinding-1 (E3 or P2 or G1)
	PG – Polishing-2 or Grinding-2 (P2 or G2)
	G3 – Grinding-3
	G4 – Grinding-4
Disc Diameter	30 mm.
Reduction Gear	3.9:1
Dimensions, WxDxH	104 x 54 x 160 mm.
Weight	1 kg.

Warranty

The MOBIPREP is guaranteed against defective material or workmanship defects for a period of 12 months from the date of receipt by the customer or latest 18 months after the shipping date. The warranty is not valid if inspection shows evidence of misuse or unauthorized repair. Warranty covers only replacement of defective materials. If this unit need to be returned to our factory for service, please contact your distributor for authorization and include the following details: Serial Number of the unit, Invoice number and date. Transport costs belong to the customer.



NOTE

The equipment is designed to be used with METKON accessories and consumables. In case of misuse of equipment, improper installation, alteration, use of different source parts, improper repair, METKON will accept NO responsibility for any damages to the operator or the equipment. Disassembling of any part should always be performed by a qualified technician



NOTE

METKON Instruments Inc. can make any changes without notice on the equipment, accessories, consumables and miscellaneous products. Consequently; visual or written information on the instruction manuals, technical materials, catalogues, website, product videos and other marketing materials may show inconsistencies and may be different from the product.

Safety Precautions

Read the below instructions carefully before use.

- The operator must be fully instructed in the use of the equipment and its accessories and consumables, according to the Instruction Manual.
- The Material Safety Data Sheet for each Metkon consumable can be reached from www.metkon.com under E-Metkon section.
- Check that the MOBIPREP is standing firmly on the support.
- Always place the MOBIPREP, micro motor, accessories and the consumables in its carrier and protection bag.
- Do not touch the electrical cable or other electrical parts with wet hands!
- When disconnecting MOBIPREP from power supply always pull the plug out. Do not pull the cable!
- Immediately disconnect MOBIPREP from power if water or any other liquid penetrates the unit!
- Do not put any metallic, flammable or other parts into MOBIPREP or to its sockets!
- Disconnect MOBIPREP from power after charging!
- Do not connect any other devices than supplied to MOBIPREP sockets!
- Do not open the control unit or change any parts within it!
- Do not touch the micro motor while it is rotating.
- When installing the accessories to the micro motor, tighten the collet chuck correctly and recheck the collet chuck before use. Do not over tighten the collet chuck. This may cause damage to the spindle.
- Do not apply excessive force. This may cause tool slippage, tool damage, and injury to the operator, loss of concentricity and precision.
- Be sure to clean the collet chuck, the inside of the spindle before replacing the grinding tool. If ground particles or metal chips stick to the inside of spindle or the collet chuck, damage to the collet chuck or spindle can occur.
- Stop working immediately when abnormal rotation or unusual vibrations are observed. Immediately, check the content of section "TROUBLESHOOTING"
- When the motor and the attachment generate heat because of continuous work, slow down the motor speed, or stop the motor. Then, use it after the motor and the attachment gets cold.
- Always check if there are any damage on the equipment and the accessories before and after operating.
- Do not disassemble, modify or attempt to repair the MOBIPREP. Additional damage will occur to the internal components. Service must be performed by METKON or an authorized service center.
- In any case of disorder, please contact your supplier or the manufacturer!

INSTALLATION & SET UP

Unpacking & Checking Contents of Package

Carefully unpack and check contents of the package. If any components are missing or damaged, save the packing list and materials and advise your distributor and the carrier of the discrepancy.

Carefully unpack and check that the following items have been received:

- MOBIPREP
- High Torque Brushless DC Motor
- 5 pcs. Grinding & Polishing Carrier
- 4 pcs. Storage box for consumables
- 90° Angle Attachment
- Protection and Transport Case



WARNING

The MOBIPREP weighs 1 kg. Please be sure that the MOBIPREP is secured in order not to turn upside down. Carefully remove outer packing material. Refer to the packing documents for a list of items supplied.

Installation and Set-Up



CAUTION

Follow approved procedures and take all necessary preventive safety measures when lifting and installing this equipment. Improper lifting can result equipment damage.

- You can see the dimensions and weight of MOBIPREP as below:

Dimensions	W	D	H
	104 mm	54 mm	160 mm
Weight	Approx. 1 kg		

Electrical Installation

The MOBIPREP is a portable equipment for field work with a rechargeable battery. Before making electrical connections for recharging, check that the voltage and frequency stated on the specification plate correspond to the local voltage and frequency. Check that the values for single-phase voltage, is compatible with the intended electrical supply before installation.



ATTENTION

Connect the unit to the grounded mains voltage.



WARNING

Electrical Shock Hazard. A qualified electrical technician should perform all hard wiring and electrical maintenance.

- Disconnect the power supply before making any electrical adjustments.
- Make sure that the supply voltage and frequency is correct. Check the values from the machine identification plate located at the rear of the machine:

Voltage / Frequency	Operational Power Range	Fuse Rating
230 V, 50/60 Hz. 1 ph.	200 - 250 V	5A [C Type]
115 V, 50/60 Hz. 1 ph.	100 - 125 V	5A [C Type]

OPERATION



MOBIPREP

CONTROL UNIT	
1	Green LED Indicator - ON
2	Red LED Indicator – Low Battery
3	Adjusting knob for Grinding/Polishing and Etching • E – Etching-1 [E1] • EP – Etching-2 or Polishing-1 [E2 or P1] • EPG – Etching-3 or Polishing-2 or Grinding-1 [E3 or P2 or G1] • PG – Polishing-2 or Grinding-2 [P2 or G2] • G3 – Grinding-3 • G4 – Grinding-4
4	Socket for Hand Guided Brushless DC Motor and Etching Pen
5	Charging Socket



Control Unit

HAND GUIDED BRUSHLESS DC MOTOR	
6	Angle Piece 90° [Alternatively Angle Piece 45° or Straight Piece]
7	Reduction Gear 4:1 [Increases rotation moment]
8	High Performance Micro Motor with click sensitive ON-OFF-Switch

Charging the Battery

To charge the built-in batteries;

- Connect the battery charger to the charging socket [#5].
- The batteries of MOBIPREP are now being charged. When the batteries are fully charged, the Battery Indicator lights green. If the batteries need charging the Battery Indicator will light red.



WARNING

A fully charged set of batteries will self-discharge in 4-6 months, and a complete discharging may reduce the lifetime. Therefore, the batteries should be charged at regular intervals.

Connection of the Attachments to the Brushless DC Motor



CAUTION

Make sure your hands and all interlocking parts of the Attachments and motor are clean before connecting the motor to the Attachment. This is critical in preventing contaminants from entering the motor or Attachment.

Reduction Gear (Reducer) Connection

- Align the threads on the front end of the motor and the rear end of the reducer, and turn the reducer clockwise.
- If the drive shaft of the motor does not engage the drive dog on the reducer, you may only turn it about 2 turns. DO NOT FORCE.
- Turn the reducer back a few threads, rotate the thread on the front end of the reducer by hand to engage the drive shaft and the drive dog, and screw them together with a provided pin wrench (spanner).
- Below photo shows the connection of the Reduction Gear (Reducer).

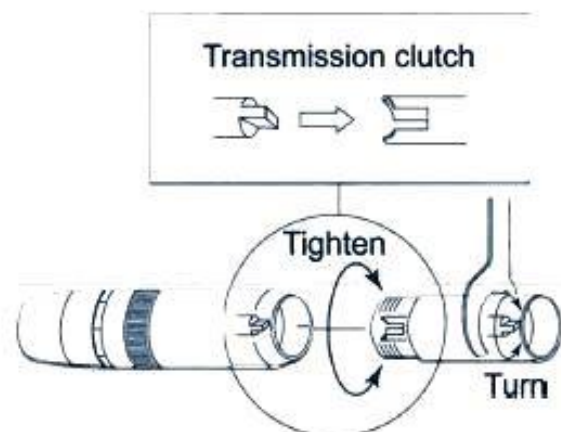

Reduction Gear (Reducer) Connection

90° and 45° Angle Attachment Connection

45° angle attachment is supplied as an optional accessory.

- Align the thread on the front end of the motor and the rear end Angle Attachment, and turn the Angle Attachment clockwise.
- If the drive shaft of the motor does not engage properly to the drive dog on the Attachment, it may only turn approximately two threads before stopping. **DO NOT FORCE!**
- In case of improper engagement loosen the Angle Attachment from the motor, rotate the Angle Attachment shaft by hand then re-try. The drive shaft and the drive dog must be fully engaged.
- When fully engaged, secure the motor and Angle Attachment using the provided pin wrench.
- Below photo shows the connection of the Angle Attachment.

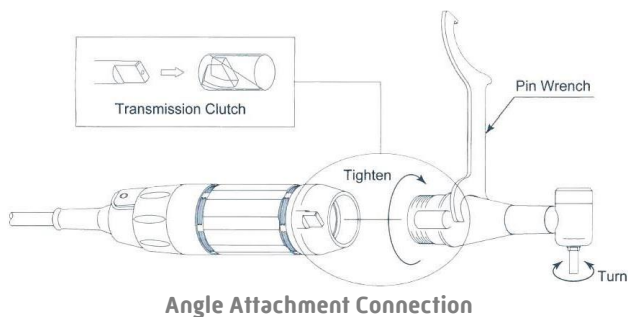

Angle Attachment Connection

Changing the Grinding and Polishing Carriers on Angle Attachment

- Attach the collet wrench provided onto the head of the Attachment. Apply light pressure to the head of the collet wrench. Place the wrench on the collet chuck.
- Turn it slowly counterclockwise. The collet wrench will engage within 90° of wrench rotation.
- Keep turning the wrench until the rod on the angle attachment can be removed.
- When mounting the grinding & polishing carriers, rotate the wrench clockwise to tighten the cutting tool firmly.
- Below photo shows the changing of the grinding & polishing carriers on Angle Attachment.

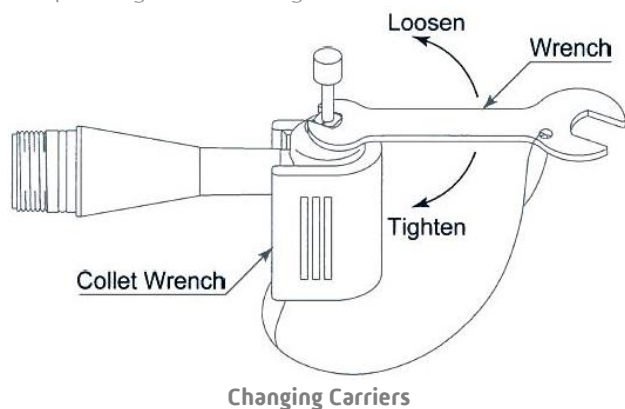

Changing Carriers

Straight Quick Release Piece Connection (Optional)

- Align the threads on the front end of the motor and the rear end attachment, and turn the attachment clockwise.
- If the drive shaft of the motor does not engage the drive dog on the attachment, you may only be able to turn it about 2 turns. **DO NOT FORCE!**
- In case of improper engagement, turn the attachment back a few threads, rotate the attachment by hand to engage the drive shaft and the drive dog, and screw them together with a provided wrench.
- Below photo shows the connection of the Straight Quick Release Piece.

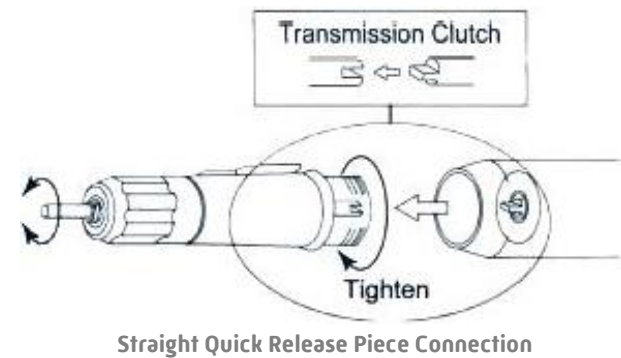

Straight Quick Release Piece Connection

Changing the Grinding and Polishing Carriers on Straight Quick Release Piece (Optional)

- Turn the lock spindle towards the arrow as shown on below photo to release the rod and remove by hand.

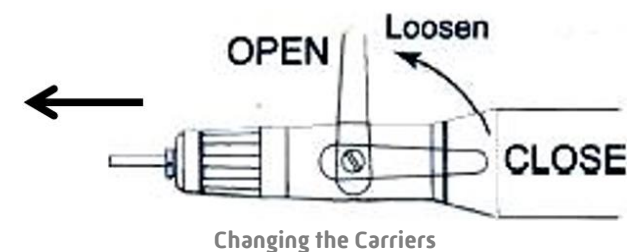

Changing the Carriers

- Mount the grinding & polishing carriers firmly and lock the spindle to the "CLOSE" position.
- If it is hard to remove the collet chuck, use the provided wrench.
- When putting high torque by cutting tools or when turning toward closing the collet chuck, there is a case where the collet chuck or cutting tools cannot be put off by hand. If so, set the provided wrench to the collet chuck; open the lock spindle [lever]. Then, turn the wrench counterclockwise to release the collet chuck or the cutting tools [below photo].

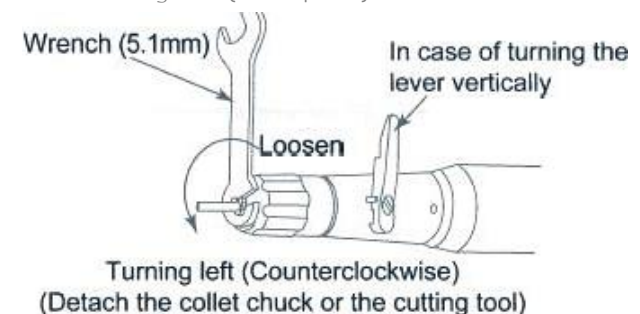

Turning left (Counterclockwise)
(Detach the collet chuck or the cutting tool)

Grinding and Polishing Operation

- Connect the hand guided device to socket #4
- Select the Grinding Mode [G] from the adjustment knob #3 for grinding.
- Place the SiC grinding paper $\varnothing 30$ mm (80-1200 grit)
- Select the Polishing Mode [P1 or P2] from the adjustment knob #3 for polishing. P1 for pre-polishing and P2 for fine polishing.
- Place the polishing cloth on the carrier as shown in below photo.

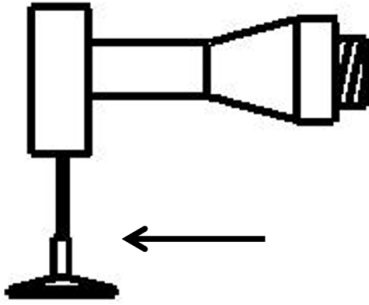

- Diamond pastes are applied to the cloth as abrasive particles of a given grain size ($9\ \mu - 6\ \mu - 3\ \mu - 1\ \mu - 0.25\ \mu$).
- Sufficient lubrication with diamond lubricant between the sample surface and the polishing cloth is necessary. It reduces friction and cools the specimen. The polishing cloth should be moist, not wet.
- The hand guided device can be switched ON and OFF directly on the micro motor (green control button).
- Light pressure is recommended during grinding and polishing.
- After grinding or polishing, between each step, the prepared spot has to be cleaned with water or with alcohol (ethanol).

Etching (Optional)

After grinding and polishing (instead of chemical etching), electrolytic etching of the prepared spot may be used with connecting the Etching Pen.

- Connect the Etching Pen to Socket #4.
- Clamp the anode (red wire) of the Etching Pen to the sample or work piece by the clamp or the magnetic anode supplied.
- Select the Etching Mode [E1 or E2] from the adjustment knob #3
- Remove the closing cap and insert a cotton-wool applicator into the Etching Pen.
- Fill the Etching Pen with the relevant electrolyte (depending on material) using the syringe by putting the syringe into the filling hole on the side of the etching pen.
- The cotton-wool applicator is soaked with the relevant electrolyte.

- Wipe the etching pen on the prepared spot until etching is done. [The mirror-like polished surface becomes darker].
- After the etching process is finished, clean the area with water or alcohol (ethanol) to stop the etching process.
- Do not over etch when using the portable microscope. For getting a replica for laboratory examination make over etching.
- When not in use the close the cap of the Etching Pen.



Etching

Recommended Electrolytes

Materials	Electrolyte	Etching	[Replacing Chemical Etching with...]
Carbon steels	Special Salt Solutions e.g. 5% NaCl solution	E2	[Nital]
Aluminum Alloys			[10% NaCl solution]
Austenitic stainless steels	10% oxalic acid	E1	[V2A-steel formulation]
High-alloyed steels (ferritic / martensitic)	Nital [3% HNO ₃ in ethanol] + water [50:50] or 3% aqueous HNO ₃	E2	[concentrated acid formulations]

Replica

The material is cellulose acetate of a thickness 35 micron (0.0014 inch) and it is soluble in acetone.

- Cut a piece of the replica material from the sheet, which is suitable to cover the area to be replicated.
- Drop one or two drops of acetone on to the specimen surface.
- Place the replica film immediately on the surface [allowing surface tension forces to pull it down; no pressure is required].
- The cellulose acetate film should be left to dry for about 10 minutes until it will splitted very easily from the surface.
- Remove the film from the surface and place between 2 cover glass slide for examination under microscope.

SERVICE AND MAINTENANCE

Maintenance

- Clean the MOBIPREP with a soft, slightly damp cloth.
- Clean the grinding & polishing carriers and the accessories before attaching to the micro motor to prevent dust and particule contamination.

Troubleshooting

ERROR	DESCRIPTION	ACTION
Overheating during rotation	Excessive force is applied during operation	Lower the force applied.
Abnormal vibration or noise during rotation	The grinding & polishing carrier is bent.	Replace the grinding & polishing carrier
Cutting Tool Slippage	Collet chuck is not correctly installed	Check and clean the collet chuck. Reinstall the collet chuck and re-tighten.
High Run Out	The grinding & polishing carrier is bent.	Replace the grinding & polishing carrier
	Collet chuck is worn	Replace the Collet chuck

ACCESSORIES AND CONSUMABLES

Accessories

Order No	Accessories for MOBIPREP
90 10	Etching-Pen for electrolytic etching
90 11	Angle piece 90 °, with 3-mm collet on
90 12	Angle piece 45 °, with 3-mm collet on
90 13	Straight quick release piece of, with 3-mm collet on
90 14	Grinding and polishing carriers (5 pieces)
90 15	Shoulder bag for Mobiprep, synthetic leather

Consumables

In-situ/Field metallography is widely used for microstructure analysis on large parts (samples) that cannot be easily carried or where destructive preparation is permissible such as storage tanks, piping system, power plants, etc. In-situ Metallography allows for quick on-site evaluation of a component. There are numerous advantages in using in-situ/field metallography.

Order No	CODE	Paper Grinding Discs, Self-Adhesive Back (1 Pack 250 Pcs.)
90 20	DEMPAX-P	SiC-grinding papers, self-adhesive, 250 pieces (• 30 mm), 80 Grit
90 21	DEMPAX-P	SiC-grinding papers, self-adhesive, 250 pieces (• 30 mm), 120 Grit
90 22	DEMPAX-P	SiC-grinding papers, self-adhesive, 250 pieces (• 30 mm), 320 Grit
90 23	DEMPAX-P	SiC-grinding papers, self-adhesive, 250 pieces (• 30 mm), 500 Grit
90 24	DEMPAX-P	SiC-grinding papers, self-adhesive, 250 pieces (• 30 mm), 800 Grit
90 25	DEMPAX-P	SiC-grinding papers, self-adhesive, 250 pieces (• 30 mm), 1200 Grit

Order No	CODE	Polishing Cloth Self-Adhesive (1 Pack 50 pcs.)
90 26	PORTO	Polishing Cloth (30 mm) for 0.25, 1, 3 microns (50 pcs.)
90 27	RADO	Polishing Cloth (30 mm) for 6, 9 microns (50 pcs.)

Order No	CODE	Diamond Pastes, Monocrystalline
39-301-M	DIAPAT-M	Diamond Paste, 0.25 μm , 10gr. syringe
39-311-M	DIAPAT-M	Diamond Paste, 1 μm , 10gr. syringe
39-321-M	DIAPAT-M	Diamond Paste, 3 μm , 10gr. syringe
39-331-M	DIAPAT-M	Diamond Paste, 6 μm , 10gr. syringe
39-341-M	DIAPAT-M	Diamond Paste, 9 μm , 10gr. syringe

Order No	CODE	Diamond Lubricant
39-502	DIAPAT	Diamond Lubricant, Water-based, 1 lt bottle

Order No	CODE	Replica Set & Etching Consumables
90 28		Cotton rolls (100 pcs) for electrolytic etching
90 40	REPLI	Replica foil 35 microns thick, to be used with acetone
90 41		Microscope slide glasses

TECHNICAL DOCUMENTATION

Customer Service

Our factory-trained assembly personal is at your disposal for customer service.
Please contact the following address:

Head Quarter

Metkon Instruments Inc.

Demirtas Dumlupinar Organize Sanayi Sitesi

Ali Osman Sonmez Cad. No: 14 Bursa/TURKEY

Tel: +90 (224) 261 1840

Fax: +90 (224) 261 1844

E-Mail: metkonsales@metkon.com

Web: www.metkon.com



MicroscopeWorld

info@microscopeworld.com | 800-942-0528

METKON
Instruments Inc.

Demirtas Dumlupinar Organize Sanayi Bolgesi
Ali Osman Sonmez Cd. No: 14 Bursa

Tel : +90 224 261 18 40
Fax : +90 224 261 18 44

metkonsales@metkon.com
metkon.com



QUARTER CENTURY OF
EXPERIENCE