



INSTRUCTION MANUAL



MEIJI TECHNO CO.,LTD.

JAPAN

	Page
INSTRUCTION	3
ASSEMBLY INSTRUCTIONS	4
USE	
Installing the Eye Guards	6
Installing the Eyepieces	6
Adjusting the Interpupillary Distance	6
Determining the Correct Eyepoint	6
Eyeglass Wearers	6
Standard Binocular Head	7
Ergonomic Binocular Head	7
Adjusting the Viewing Height	7
Adjusting for Specimen Height	7
Focus Controls	7
Tension Controls	8
Changing the Magnification	8
Magnification Index	8
Dioptric and Parfocality Adjustment	8
Dioptric and Parfocality Adjustment with Eyepiece Reticle	9
Double Iris Diaphragm	9
Coaxial Vertical Illuminator	9
STANDS	
RZP Plain Stand	10
RZT Transmitted Light Stand	11
RZDT Brightfield/Darkfield Transmitted Light Stand	11
RZBD Brightfield/Darkfield Transmitted Light Stand	12
MAC Universal Boom Stand	12
ILLUMINATORS	
COX Coaxial Vertical Illuminator	14
Oblique Illumination	10
Annular Illumination	10
Fluorescent Ring Illumination	10
STAGES	
Graduated Mechanical Stage for RZP	13
Graduated Mechanical Stage for RZT, RZDT, RZBD	13
Ungraduated Mechanical Stage for RZP	13
Ungraduated Mechanical Stage for RZT, RZDT, RZBD	13
Polarizing Stage for RZT, RZDT, RZBD	13
PHOTOMICROSCOPY AND VIDEOMICROSCOPY PARTS AND ACCESSORIES	
MA751 Photo/Video Attachment	15
MA752 Auxiliary Video Attachment	16
35mm Photomicroscopy Equipment	17
Installing MA150/50 and MA150/60 Camera Attachment	18
Using the MA150/50 and MA150/60 Camera Attachment	19-20
Large Format Photomicroscopy Equipment	21
Using the Framing Reticle	22
Installing MA752 Auxiliary Video Attachment "C" Mounts	24
Installing MA751 Photo/Video Attachment "C" Mounts	25
MA765 Drawing Attachment	25
OPTICAL DATA	26
MAINTENANCE AND CARE	27
Replacing the Bulb or Fuse	27
Bulb Replacement RZT Stand	27
Bulb Replacement RZDT Stand	27
Bulb Replacement RZBD Stand	28
Care	28
Cleaning	28

RZ Series

MEIJI TECHNO

RZ Series STEREO MICROSCOPES

The MEIJI TECHNO RZ series of advanced, high performance, modular, stereo microscopes are specifically designed with today's demanding applications in mind.

Engineered around a Common Main Objective and parallel optical paths, the RZ series offers crisp, distortion-free, high-resolution images at magnifications ranging from 3.75X to 300X.

Featuring a 10:1 zoom ratio, built-in variable double iris diaphragms, and positive detente click-stops at 12 positions of magnification. Two perpendicular columns of eight zoom lenses in four groups move in a smooth continuous motion by rotation of the ergonomically sized and positioned zoom control. A magnification indicator is conveniently located on the zoom control. The RZ series is also coated with a special anti-static finish, which is especially useful when working with sensitive electronic components.

Ergonomic and standard heads are available. The ergonomic head features low positioned eyetubes and is adjustable vertically from 10° to 50° for comfortable, fatigue-free viewing. Interpupillary distance is adjustable from 52mm to 75mm. The standard, economical binocular head is inclined at 45° with an interpupillary adjustment ranging from 46mm to 75mm.

Distortion-free, ultra wide-field eyepieces with dioptic adjustment are available in several powers of magnification and are provided with reticule mounts for measurement and photomicrography.

A coaxial coarse and fine focus mechanism with a 50mm focusing range is provided for ultra-smooth and precise focus control.

MEIJI TECHNO's RZ series offers a full range of optional modular accessories including: Ergonomic Binocular Body, Coaxial Vertical Illuminator, TV Camera Adapter, Varied Interchangeable Objectives and Widefield Eyepieces, Polarizing Filters, Brightfield Transmitted Light Stand, Brightfield/Darkfield Transmitted Light Base, Photomicrographic Systems and various other components and accessories for complete system versatility.

ZOOM STEREO MICROSCOPES

MEIJI TECHNO 

ASSEMBLY INSTRUCTIONS

Read these instructions thoroughly before attempting assembly. The RZ is a modular system, and your configuration might not include all of the parts discussed in this manual. This will affect the assembly process, so be sure that you understand how your components fit together and the order in which they should be assembled before you begin. Make sure that all exposed lens and prism surfaces on each part are clean and free of dust before assembly.

- (1) **Unpacking:** Carefully remove each part from its shipping container, and verify that you have received all items on the packing list. It is a good idea to keep the packaging material, as it is useful for future storage or transport.
- (2) **Microscope Body and Stand:** The microscope body may already be mounted on the stand. If not, loosen the set screw at the back of the body and slide the body over the vertical mounting post on the stand. Make sure that both the body set screw and the safety collar set screw are well tightened. To protect the microscope body from damage, remember to adjust the safety collar each time you raise or lower the body.
- (3) **Objective:** Screw the objective lens into the threaded opening on the bottom of the microscope body. Be careful not to drop the objective or touch the exposed lens surfaces.

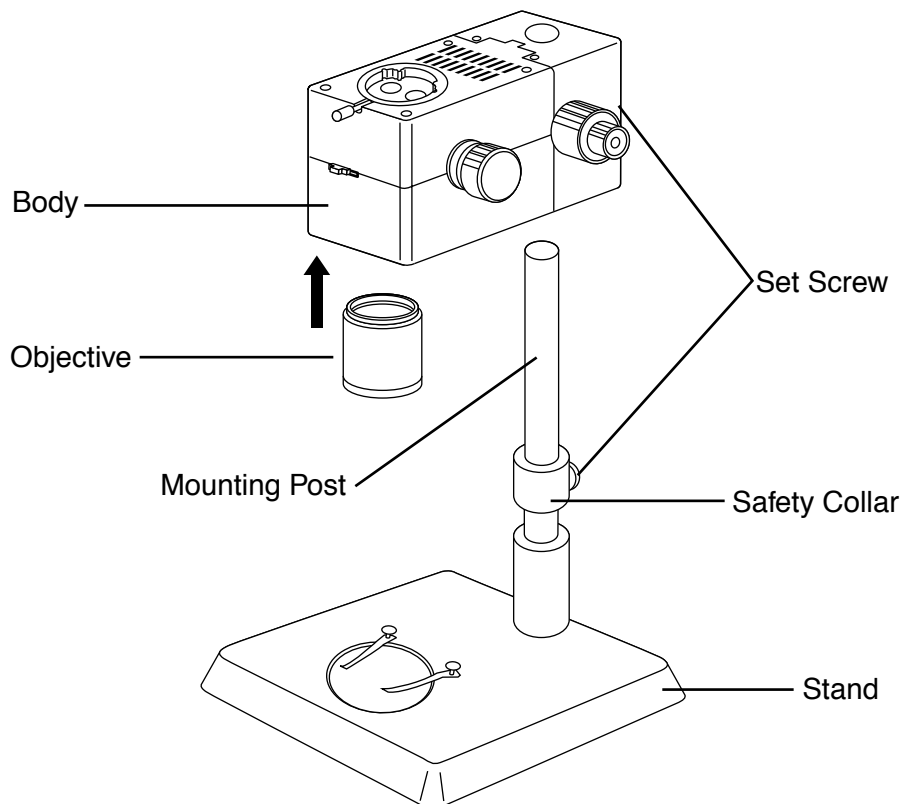

RZ Series

MEIJI TECHNO

- (4) **Viewing Head:** A basic RZ system will have the viewing head mounted directly to the microscope body. However, if your system includes the COX Coaxial Illuminator or the MA751 Photo/Video Attachment, these items must be installed before the head is mounted (see Page 15). The dovetail on the bottom of the viewing head (ergonomic or standard) fits into the mount on the top of the microscope body. Loosen the set screw on the upper front of the body, and place the viewing head into the mount. The guide pin at the back of the mount should fit into the slot at the rear of the dovetail. Re-tighten the set screw to hold the head firmly in place.
- (5) **Eyepieces:** Loosen the set screws on the eyepieces and slide them over the eyetubes on the viewing head until they are fully seated. Orient the set screws downwards, tighten them, and set the diopter adjustment rings on both eyepieces to zero (see diagram).

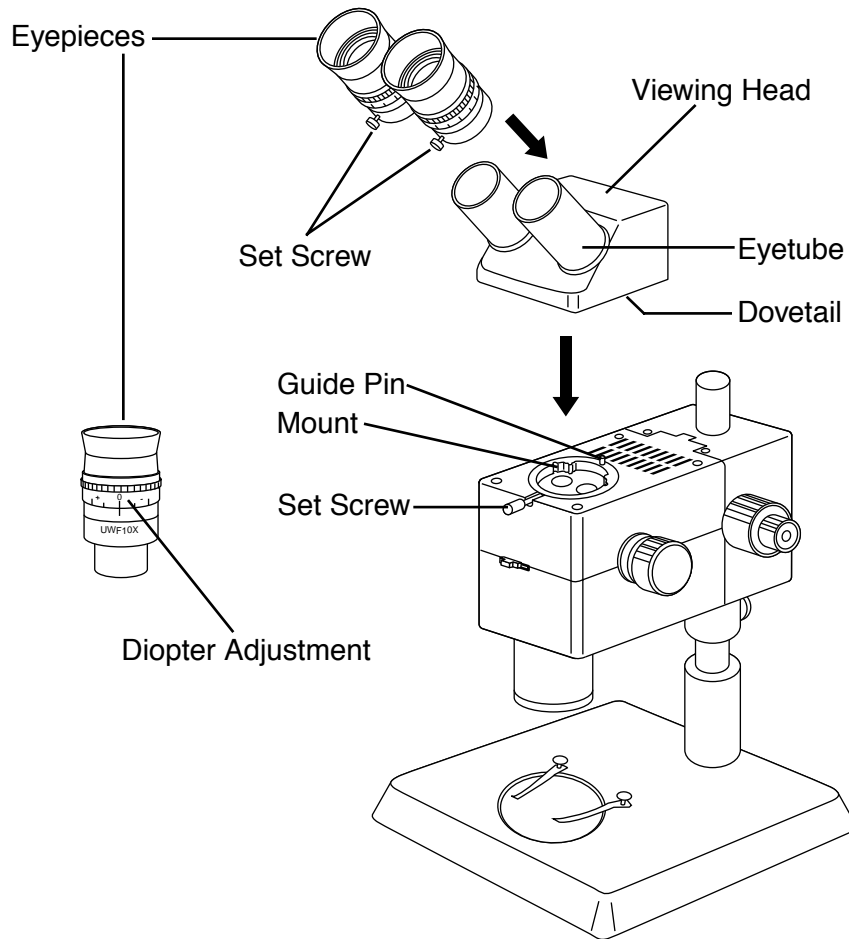

ZOOM STEREO MICROSCOPES

MEIJI TECHNO 

INSTALLING THE EYE GUARDS

Each eyepiece is provided with a protective rubber eye guard. Use of the rubber eye guard protects the optical surface of the eyepiece from accidental damage and prevents stray light from interfering with the image you are viewing. The protective eye guard simply slips over the viewing end of each eyepiece until it is firmly seated.

INSTALLING THE EYEPIECES

Loosen the set screws on the eyepieces and insert them into the eyetubes on the viewing head until they are fully seated. Orient the set screws downwards, tighten them, and set the diopter adjustment rings on both eyepieces to zero. The dioptic range is from +5 to -5.

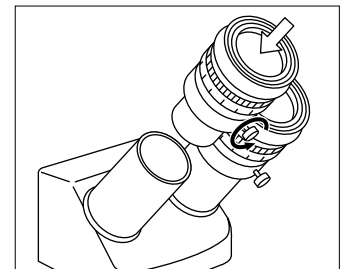

ADJUSTING THE INTERPUPILLARY DISTANCE

The correct interpupillary distance is achieved when the viewer observes a single circular field of view when using both eyes to view a specimen. The interpupillary distance is set by moving the eyetubes closer together or farther apart. The interpupillary distance will vary from individual to individual. Interpupillary distance range: Standard head 46mm ~75mm, Ergonomic head 52mm ~75mm.

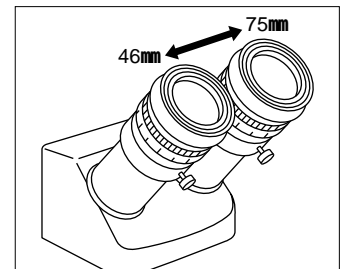

DETERMINING THE CORRECT EYEPOINT

The eyepoint of the eyepiece is the distance from the eyepiece to the pupil of the eye. To find the eyepoint or correct viewing position move your eyes closer to the eyepiece until the image of the specimen and the entire field of view is observed without restriction.

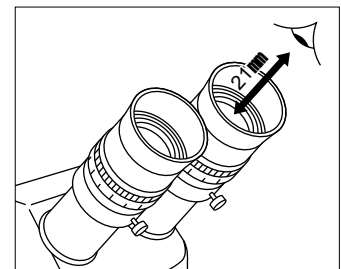

EYEGLOSS WEARERS

If you are an eyeglass wearer and the rubber eye guards interfere with viewing of the specimen then fold the eye guards back upon themselves to give you more distance between the eyepiece and your eyeglasses.

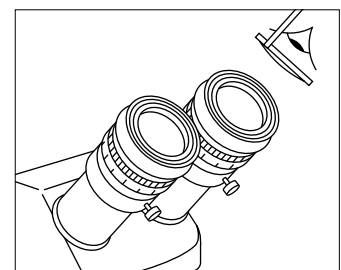

RZ Series

MEIJI TECHNO

STANDARD BINOCULAR HEAD

The standard binocular head is inclined at 45 degree. The interpupillary distance is adjustable from 46mm to 75mm.

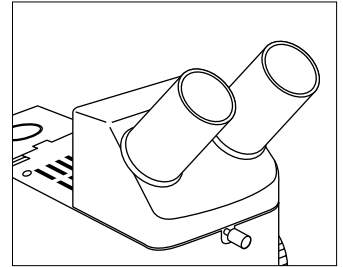

ERGONOMIC BINOCULAR HEAD

The ergonomic binocular head viewing angle is adjustable from 10° to 50° and the interpupillary distance is adjustable from 52mm to 75mm.

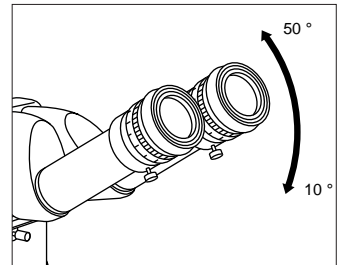

ADJUSTING THE VIEWING HEIGHT

The viewing height is correctly adjusted when your body, neck and back are positioned to avoid fatigue and strain. In the case of the ergonomic head the viewing angle (10° ~50°) can be adjusted by holding the eyepiece tubes and swinging them upwards or downwards.

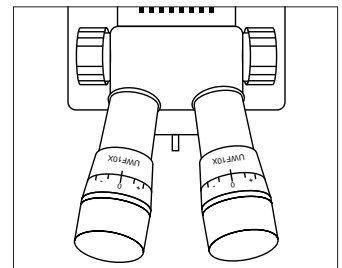

When using the standard viewing head the eyetubes are fixed and the viewing height can only be adjusted by increasing or decreasing the height of your worktable or chair.

ADJUSTING FOR SPECIMEN HEIGHT

Set the diopter adjustments to zero. Place a specimen beneath the microscope objective. Zoom to the lowest end of the zoom range (7.5). Loosen the clamp screw holding the microscope body on the stand while supporting the weight of the body with your free hand. Raise and lower the body while looking through the eyepieces until the image is roughly in focus. Tighten the clamp screw.

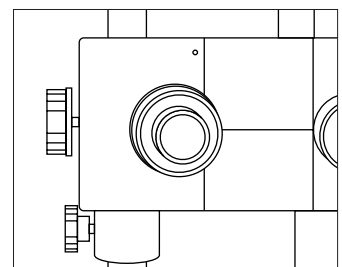

FOCUS CONTROLS

The coaxial coarse and fine focus controls are located on each side of the microscope body and can be operated from either side of the microscope. The coarse focus control rotates a full 360° and allows the microscope to travel vertically over a distance of 50mm or 2 inches.

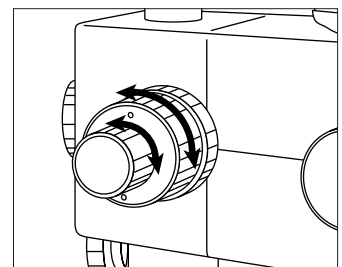

ZOOM STEREO MICROSCOPES

MEIJI TECHNO 

TENSION CONTROL

The tension control adjustment is located on the left side of the microscope body directly behind the coaxial coarse focus control. Rotating the tension control ring clockwise decreases the tension on the focus control mechanism. Rotating the tension control ring counter-clockwise increases the tension on the focus control mechanism. The tension control can be set to the user's preference.

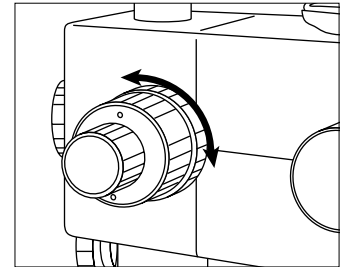

CHANGING THE MAGNIFICATION

The RZ series microscopes have a continuous zoom range with a 10:1 zoom ratio and positive detente click stops at twelve positions of magnification. The zoom controls are located on each side of the microscope and can be operated from either side of the microscope. Rotate the controls clockwise to increase the magnification and counter-clockwise to decrease the magnification.

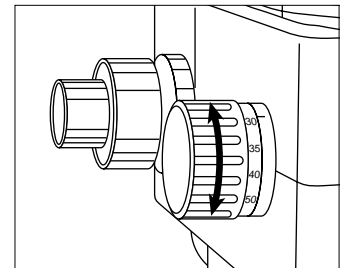

MAGNIFICATION INDEX

The magnification index shows the actual magnification to the viewer when the standard 1.0X objective and 10X eyepiece are used. Please refer to the optical data table on Page 26 to determine the total magnification for various optional eyepiece/objective combinations.

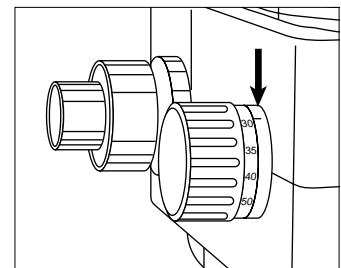

DIOPTRIC AND PARFOCALITY ADJUSTMENT

Set the dioptic adjustment rings on both eyetubes to zero. Place a flat specimen on the microscope stage beneath the objective. Zoom the microscope to the highest end of the zoom range. Focus on the specimen using the coarse and fine focus controls. Zoom the microscope to the lowest end of the zoom range. Close your left eye and look into the right eyepiece with your right eye. Slowly rotate the diopter adjustment ring + or - until the image is sharply focused. Close your right eye and look into the left eyepiece with your left eye. Slowly rotate the diopter adjustment ring + or - until the image is sharply focused. Zoom the microscope from the low to high position while viewing the flat specimen. The image should remain in focus throughout the entire zoom range.

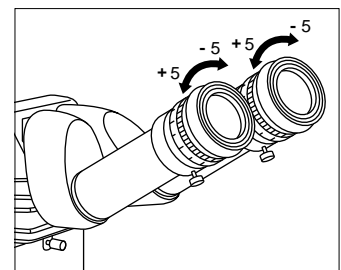

RZ Series

MEIJI TECHNO

DIOPTRIC AND PARFOCALITY ADJUSTMENT WITH EYEPIECE RETICLE

Install the eyepiece containing the reticle into the right eyetube. Focus the right eyepiece on the image of the reticle by rotating the dioptic adjustment rings + or - until the image of the reticle is sharply in focus. Place a flat specimen on the microscope stage beneath the objective. Zoom the microscope to the highest end of the zoom range (75). Focus on the specimen using the coarse and fine focus controls. Zoom the microscope to the lowest end of the zoom range (7.5). Close your right eye and look into the left eyepiece with your left eye. Slowly rotate the diopter adjustment ring + or - until the image of the specimen is sharply focused. Zoom the microscope from the low to high position while viewing the flat specimen. The image of the eyepiece micrometer should remain in focus throughout the extended zoom range. The image of the specimen *will not* remain in focus throughout the extended zoom range. Refocus on the specimen using the coaxial coarse and fine focus controls.

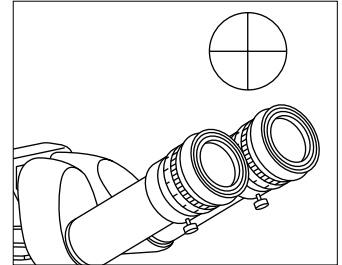

DOUBLE IRIS DIAPHRAGM

The double iris diaphragm control is located on the front of the microscope body. Closing down the iris diaphragm enhance contrast and increases the depth of focus. When the double iris diaphragm is closed down the image brightness is decreased slightly and exposure times for photographs are increased. When the double iris diaphragm is closed down the resolution is also slightly reduced.

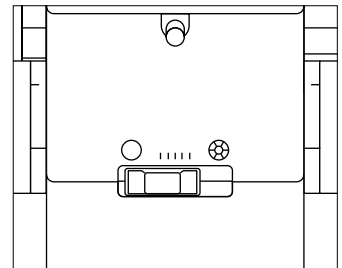

COAXIAL VERTICAL ILLUMINATOR

The coaxial vertical illuminator is used when observing flat, highly reflective specimens such as integrated circuits, semiconductor wafers, polished metal specimens, solder balls or magnetic recording heads. The coaxial vertical illuminator fits between the binocular head and the main body of the microscope and may be used in conjunction with photo/video attachment. A *quarter wave plate is required when using the coaxial vertical illuminator to view reflective specimens.* The quarter wave plate is attached to the bottom of the objective and is rotated to achieve the desired effect. Use of the coaxial illuminator increases the total magnification to the viewer by a factor of 1.5X. *Optional optical filters are available and are listed in the COX illuminator section of this manual.* The light source for the coaxial vertical illuminator is a 6V, 30W halogen bulb.

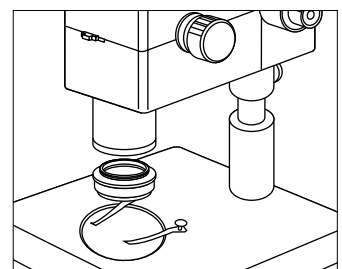
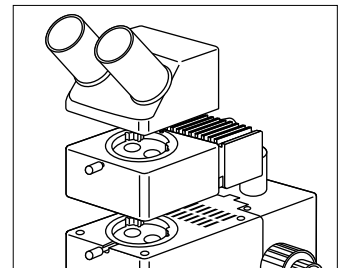

ZOOM STEREO MICROSCOPES

MEIJI TECHNO 

OBLIQUE ILLUMINATION

Dual-arm fiber optic illumination system is available for oblique illumination. Composed of a 150W halogen light source, self-supporting, dual-arm fiber light guides, adapter and focusing lenses.

Cat. No. FL181 (110V), FL181/220 (220/240V)

Replacement Bulb: Cat. No. FL180/70

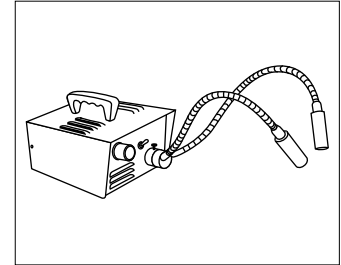

ANNULAR ILLUMINATION

An annular fiber optic light system is also available for the RZ series stereo microscopes. Composed of a 150W halogen light source and annular light guide.

Cat. No. FL182 (110V), FL182/220 (220/240V)

Replacement Bulb: Cat. No. FL180/70

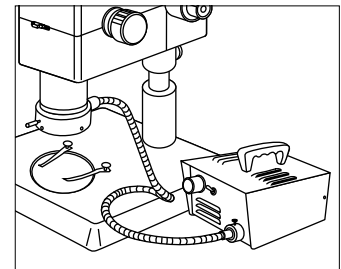

FLUORESCENT RING ILLUMINATION

The MA305/100 (110V) or MA305/200 (220/240V) Fluorescent Ring Illuminators provide cool, white, diffuse illumination similar to daylight. Suitable for low magnification examination of delicate organisms that are sensitive to heat, or for specimens subject to surface reflection. The MA308 adapter is necessary to attach the MA305 illuminator to the RZ series microscope.

Illuminator: Cat. No. MA305/100 or MA305/200

Adapter: Cat. No. MA308

Replacement Bulb: Cat. No. MA305/05

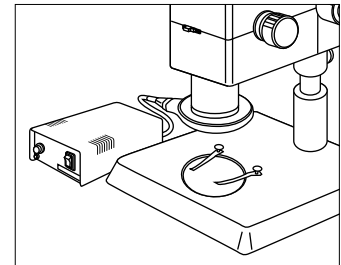

RZP PLAIN STAND

The RZP Plain Stand consists of an anti-static finished aluminum alloy base with a 95mm diameter black and white plastic stage plate and two stage clips.

Base Dimensions: 280mm wide x 255mm deep x 35mm high

Pillar Height: 325mm

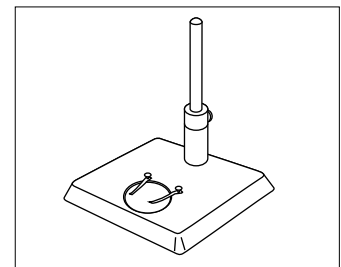

RZ Series

MEIJI TECHNO

RZT TRANSMITTED LIGHT STAND

The RZT Transmitted Light Stands are used for brightfield observation of transparent specimens. The RZT features a 6V 30W halogen lamp with variable intensity control, 95mm diameter clear glass stage plate, two stage clips and an anti-static finish. A second transformer is incorporated into the base for use with the optional COX illuminator or auxiliary light source.

Base Dimensions: 280mm wide x 255mm deep x 85mm high

Pillar Height: 325mm

Model No. RZT/100 (110 Volt), RZT/200 (220/240 Volt)

Replacement Bulb: Cat. No. MA326

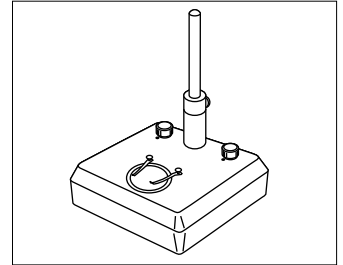

RZDT BRIGHTFIELD/DARKFIELD TRANSMITTED LIGHT STAND

The RZDT Transmitted Light Stands are used for brightfield/darkfield observation of transparent specimens. The RZDT features a 12V 30W halogen lamp with variable intensity control, 95mm diameter clear glass stage plate, two stage clips and an anti-static finish. Quick change over from brightfield to darkfield observation is facilitated by easy to reach, front-mounted controls. A second transformer is incorporated into the base for use with the optional COX illuminator or auxiliary light source.

Base Dimensions: 280mm wide x 255mm deep x 85mm high

Pillar Height: 325mm

Model No. RZDT/100 (110 Volt), RZDT/200 (220/240 Volt)

Replacement Bulb: Cat. No. MA275/05

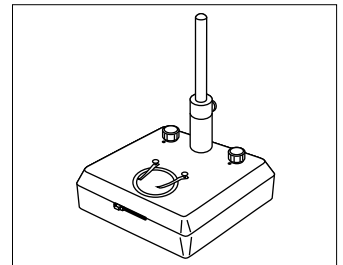

ZOOM STEREO MICROSCOPES

MEIJI TECHNO 

RZBD BRIGHTFIELD/DARKFIELD TRANSMITTED LIGHT STAND

The RZBD transmitted light stand is used for brightfield/darkfield observation of transparent specimens. The RZBD stand incorporates an annular optic light guide and an external 150W halogen light source.

The RZBD stand features an anti-static paint-coated aluminum alloy base which includes a 95mm diameter clear glass stage plate, two stage clips and a built-in brightfield/darkfield baffle. Quick change over from brightfield to darkfield observation is facilitated by easy-to-reach front mounted controls.

Base Dimensions: 280mm wide x 255mm deep x 85mm high

Pillar Height : 325mm

Light source Dimensions: 150mm wide x 230mm deep x 130mm high

Model No. RZBD/100 (110 volt), RZBD/200 (220/240 Volt)

Replacement Bulb : Cat. No. FL180/70

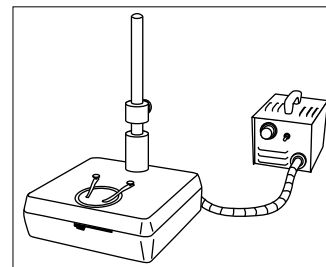

MAC UNIVERSAL STANDS

Universal boom stand for special applications involving large specimens. Features a 506mm vertical post with hand-operated crank for easy vertical positioning. The 460mm horizontal articulated arm with lockable joints allows the RZ to be swung easily into position. Available in three versions:

MAC-1: Without mounting post

MAC-2: With fixed vertical mounting post

MAC-3: With tilting mounting post

Base Dimensions: 305mm x 305mm x 38mm

Pillar Height: 483mm

Swing Arm: 445mm from column center to drop post center

Weight: 38.7kg

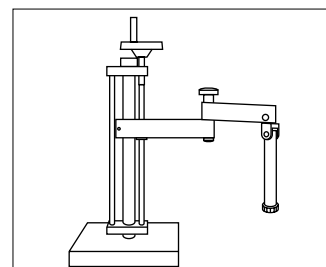

RZ Series

MEIJI TECHNO

GRADUATED MECHANICAL STAGE FOR RZP

This stage has 0.1mm graduations and coaxial controls for precise control of mounted specimens. Features 116mm x 137mm work surface with stage clips, 50mm x 75mm X-Y travel.

Cat. No. MA578

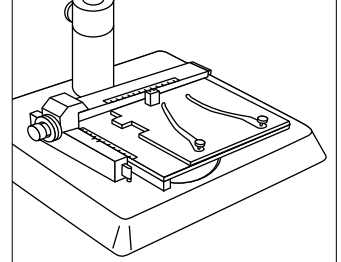

GRADUATED MECHANICAL STAGE FOR RZT, RZBD, RZDT

This stage has 0.1mm graduations and coaxial controls for precise control of mounted specimens. Features 116mm x 137mm work surface with stage clips and 74mm x 96mm clear glass plate for use with transmitted light stands, 50mm x 75mm X-Y travel.

Cat. No. MA578/05

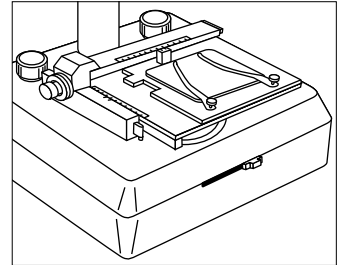

UNGRADUATED SLIDING MECHANICAL STAGE FOR RZP

This stage features a 125mm x 170mm work surface with stage clips. Roller bearing mount allows smooth, easy, fingertip control over 100mm x 100mm X-Y travel.

Cat. No. MA565

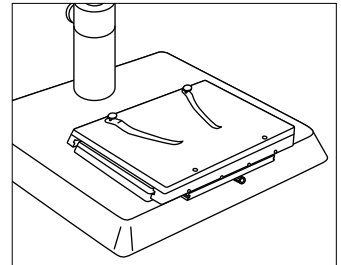

UNGRADUATED SLIDING MECHANICAL STAGE FOR RZT, RZBD, RZDT

This stage features a 125mm x 170mm work surface with stage clips and a 94.5mm diameter clear glass plate for use with transmitted light stands. Roller bearing mount allows smooth, easy, fingertip control over 100mm x 100mm X-Y travel.

Cat. No. MA565/05

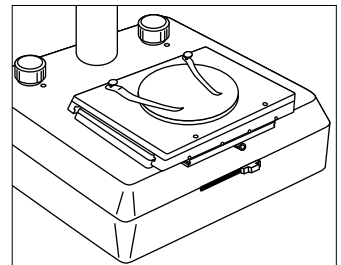

POLARIZING STAGE (fits RZT, RZBD and RZDT)

150mm diameter rotatable stage with 1° vernier markings and detent. Includes 1st order red and quarter wave plates in sliding mounts, and stage clips.

Cat. No. MA761

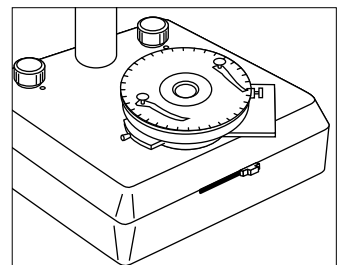

COX COAXIAL ILLUMINATOR

The **COX Coaxial Illuminator** directs light from a 6V 30W halogen lamp (replacement bulb: MA326) down through the objective lens onto your specimen and increases the microscope magnification by a factor of 1.5X. This vertical lighting is especially useful for viewing highly reflective surfaces such as solder balls, integrated circuits, wafers, or magnetic recording heads, as well as for illuminating small pits and other surfaces that would otherwise be in shadow. The MA762 quarter wave plate (ordered separately) is required for use with the COX to reduce glare and reflection. The COX also has dual filter slots that accept these five optional filters:

- MA754 LB100 clear blue
- MA755 G533 clear green
- MA756 Y48 clear yellow
- MA757 ND2 neutral density
- MA758 ND8 neutral density

If you have a transmitted light stage (RZT, RZBD, RZDT) the COX draws power from a socket at the rear of the base. If you do not have one of these stands, you will need the MA651/05 (115V) or the MA651/10 (220V) power supply to provide 6V 30W current to the COX.

INSTALLATION:

The COX mounts directly to the RZ body below the viewing head using the same dovetail/guide pin/slot mount as the viewing head. If the head is already installed, remove it. Loosen the set screw on the upper front of the body, and place the dovetail on the bottom of the COX into the mount. The guide pin at the back of the mount should fit into the slot at the rear of the dovetail. Re-tighten the set screw to hold the COX firmly in place. If your system includes an MA751 photo/video attachment, it should be mounted in the same manner to the top of the COX (see Page 15). If not, mount the viewing head to the top of the COX. Finally, connect the COX plug to the socket either at the rear of the base or at the rear of the additional power supply.

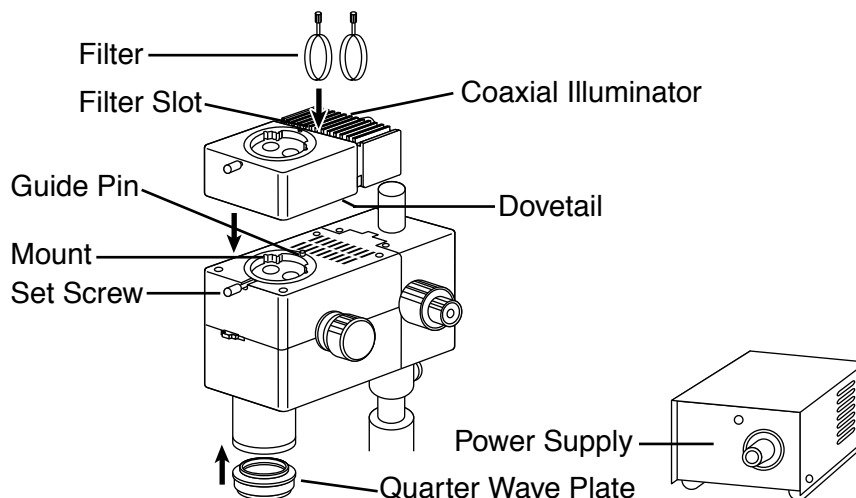

RZ Series

MEIJI TECHNO

PHOTOMICROSCOPY AND VIDEOMICROSCOPY PARTS AND ACCESSORIES

The primary component necessary for photo or video work with the RZ stereo microscope is the **MA751 Photo/Video Attachment**. The MA751 allows you to take 35mm or large-format Polaroid photographs of your specimens, or to display your specimens on a video monitor. If you wish to photograph specimens while simultaneously displaying them on a video monitor, you can do so by attaching the **MA752 Auxiliary Video Attachment** to the MA751 photo/video attachment. (*Note: You must have an MA751 to use the MA752.*)

MA751 PHOTO/VIDEO ATTACHMENT

The **MA751 Photo/Video Attachment** contains a beam-splitter prism which redirects 80% of the light that would normally go to the eyepieces into the vertical photo tube behind the viewing head. This is accomplished by means of the beam-splitter slider control on the right side of the photo/video attachment below the viewing head (marked "BI/PHOTO" and "BI"). With the slider control in the "BI" position, the microscope functions normally with 100% of the light directed through the eyepieces. With the slider control in the "BI/PHOTO" position, the beam-splitter prism redirects 80% of the light through the photo tube (and auxiliary video attachment, if installed) and 20% through the eyepieces. This allows you to view the specimen through the eyepieces while also taking photographs and/or displaying the image on a video monitor. (Further accessories are needed to attach 35mm or video cameras to the MA751; see below)

INSTALLATION:

The photo/video attachment uses the same dovetail/guide pin/set screw mount as the viewing head and coaxial illuminator, so follow the mounting procedure described on Page 5 and 15 to mount the MA751 to the RZ body. Then mount the viewing head to the MA751 in the same manner. If you are also using the COX coaxial illuminator, it must be mounted on the RZ body first. The MA751 then mounts to the top of the COX, and the viewing head to the top of the MA751.

MA751
Photo/Video Attachment

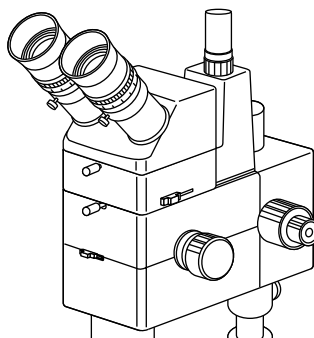
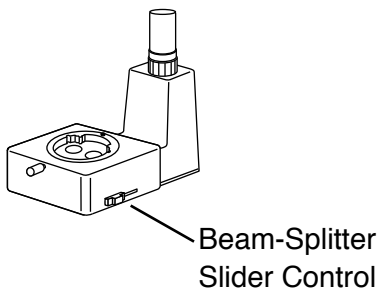

Assembly Units
with COX Coaxial Illuminator

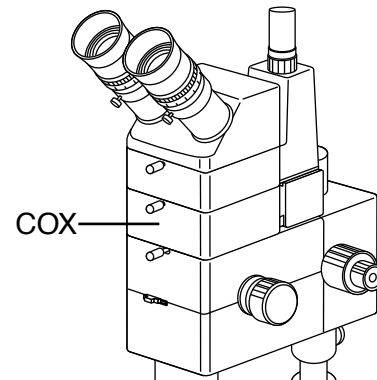

ZOOM STEREO MICROSCOPES

MEIJI TECHNO 

MA752 AUXILIARY VIDEO ATTACHMENT

The MA752 Auxiliary Video Attachment attaches to on the left side of the MA751 photo/video attachment and allows you to mount an additional video camera to the microscope. A standard “C” mount (MA151/10) for attaching a video camera is included in the MA752, so if you have a camera and monitor, no further accessories are required. (Optional “C” mounts are also available; see below)

INSTALLATION

Insert the black tube on the auxiliary video attachment into the port on the left side of the MA751 photo/video attachment below the viewing head. The guide pin on the tube mount fits into the port. Then tighten the silver locking ring on the tube mount onto the threads around the port until the video camera attachment is securely locked in place.

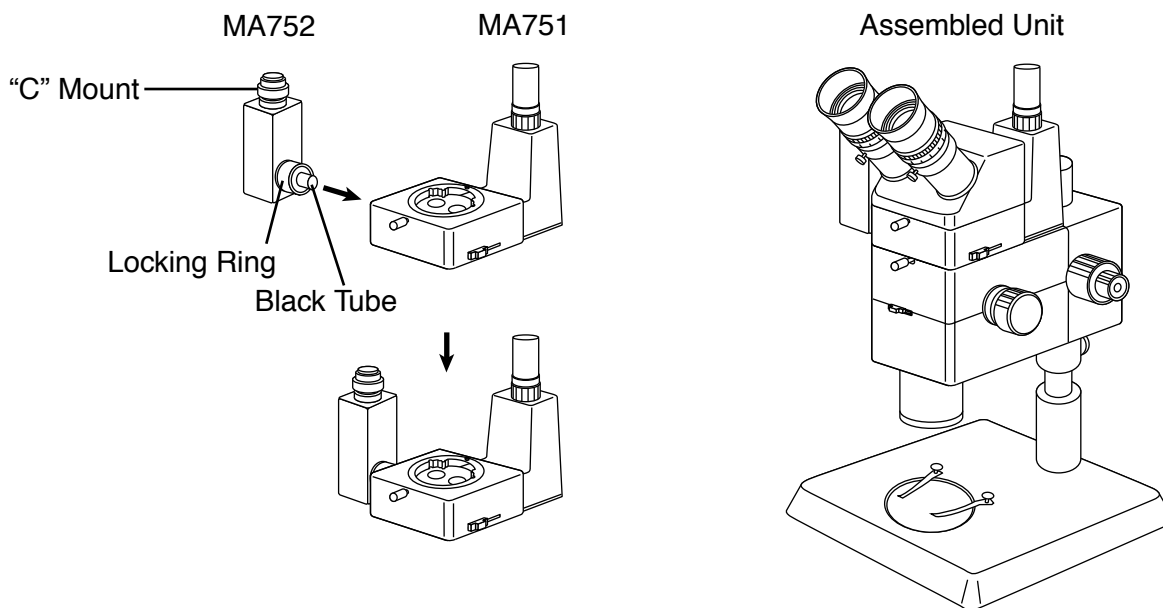

RZ Series

MEIJI TECHNO

35mm PHOTOMICROSCOPY EQUIPMENT

Three parts are required for mounting a 35mm SLR camera body to the MA751 Photo/Video Attachment:

1. The appropriate **T-2 Adapter Ring** for your SLR camera body:

T2-1	Canon	T2-6	Olympus
T2-2	Minolta	T2-7	Contax, Yashika
T2-3	Pentax K	T2-8	Konica
T2-4	Pentax S (threaded)	T2-9	Canon EOS
T2-5	Nikon	T2-10	Minolta Alpha/Maxim 2000

These adapter rings attach directly to your camera body's lens mount.

2. A **Photo Eyepiece**. Available in the following magnifications:

MA512	2.5X magnification
MA500	3.3X magnification
MA508	5X magnification

The photo eyepiece performs the same function as a standard 35mm camera lens (i.e. focusing the image at the plane of the film).

3. A **MA150 series Camera Attachment**:

MA150/50	Straight-tube camera attachment
MA150/60	Camera attachment with built-in focusing eyepiece

These are used to mount the camera/T2 assembly to the photo tube.

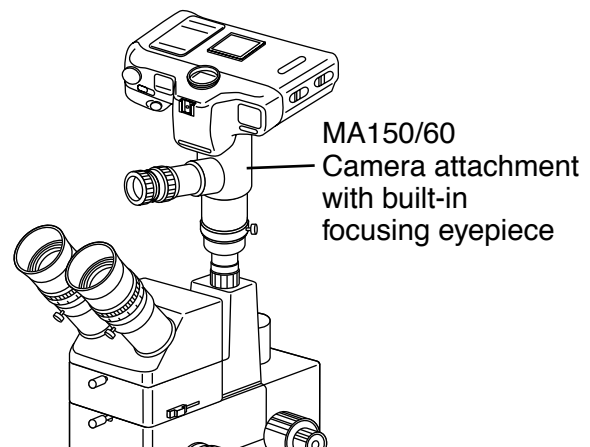
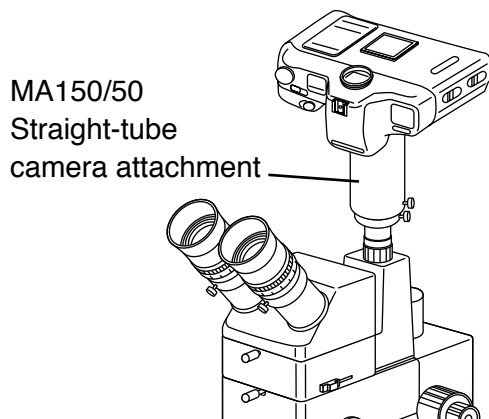

ZOOM STEREO MICROSCOPES

MEIJI TECHNO 

INSTALLING MA150/50 AND MA150/60

The **MA150/50** is comprised of two parts held together by a set screw: a small mounting flange that fits over the photo tube and locks down with a second set screw, and a larger upper tube with a threaded end to accept the T2 adapter that is attached to your camera body. To assemble these parts, first attach the T2 adapter to your camera body. Next separate the two halves of the MA150/50 camera attachment, slide the small mounting flange portion over the photo tube, and tighten the set screw. Then drop the photo eyepiece into the open top of the photo tube. Take the upper tube of the MA150/50 camera attachment and screw it into the T2 adapter mounted on your camera body. Finally, re-attach the opposite end of the MA150/50 upper tube to the MA150/50 mounting flange on the photo tube and tighten the set screw so that the entire assembly is stable.

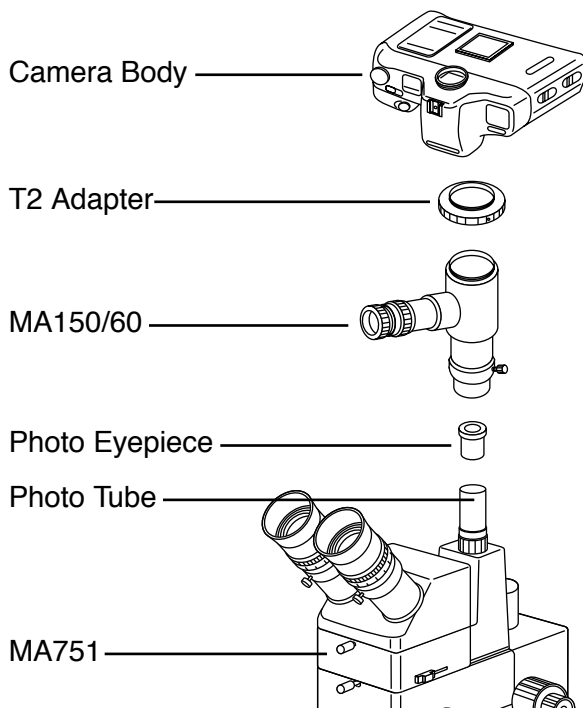
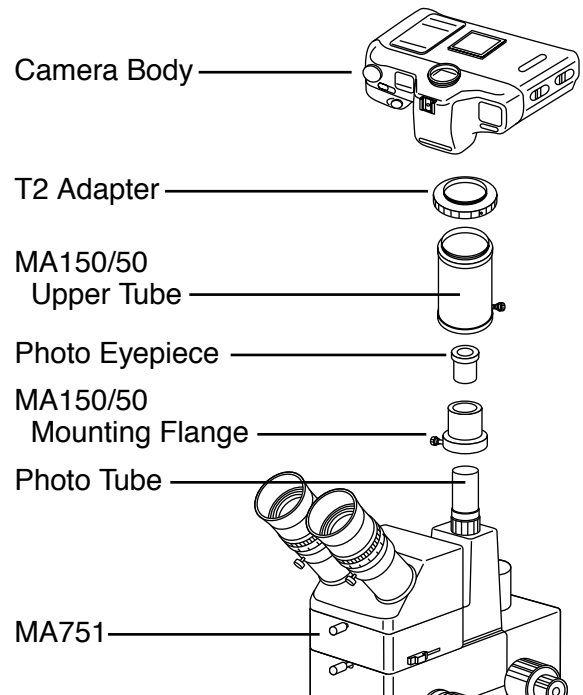

The **MA150/60** has a focusing eyepiece with a photo sizing reticle built in. This enables you to focus the image at the plane of the film more easily than if you are looking through the camera's viewfinder. Unlike the MA150/50, the MA150/60 is a single-piece unit, so assembly is slightly different. First attach the T2 adapter to your camera body, then screw the threaded end of the MA150/60 into the T2 adapter. Next, drop the photo eyepiece directly into the photo tube, slide the lower end of the MA150/60 over the photo eyepiece, and tighten the set screw onto the photo tube so that the entire assembly is stable.

USING THE MA150/50 AND MA150/60 CAMERA ATTACHMENTS

Taking high quality photographs through a microscope takes a little practice, but the basic steps that you will need to follow are really quite simple. First of all, it is important that your microscope's interpupillary, diopter, and illumination settings are properly adjusted (see Pages-in this manual). When this has been done, the next step is to "parfocal" the microscope and camera.

PARFOCALLING THE MA150/60 35mm CAMERA ASSEMBLY

When you use the MA150/60 camera attachment there are actually three ways you can view the image of your specimen: through the eyepieces of the microscope: through the camera viewfinder, or through the focusing eyepiece on the MA150/60.

The word "parfocal" means that when the image of the specimen is in focus through one of the viewing positions it is also clearly focused in the other viewing positions.

It is only necessary to have the image focused at the plane of the film (i.e. as seen through the camera viewfinder) in order to take clear photographs, but when the microscope and attachment are properly adjusted or "parfocal" to each other it is much easier to take sharp pictures. Follow these steps to ensure that it is:

(1) Look through the microscope eyepieces, bring the image you wish to photograph into focus. Then pull out the beam splitter knob to redirect the image to the photo tube.

(2) Look through the focusing eyepiece of the MA150/60 camera attachment. Rotate and adjust the outer part of the focusing eyepiece until the center double crossline on the framing reticle comes clearly into focus. At this point the image of the specimen is in focus when viewed through the eyepieces of the microscope and the image of the crossline is in focus when viewed through the focusing eyepiece. The next step is to bring the image of the specimen into focus through the focusing eyepiece.

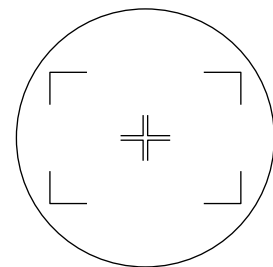

Framing Reticle

(3) Look through the focusing eyepiece on the MA150/60. If the image of the specimen is not clear, you can bring it into focus by adjusting the height of the MA150/60 camera attachment on the photo tube. The photo tube is threaded where it mates to the microscope body, and its height is adjusted by screwing it farther into or out of the body. To do so, loosen both the locking ring on the photo tube and the set screw that holds the MA150/60 on the photo tube. This allows you to turn the photo tube and adjust its height without having to turn the camera. Look through the focusing eyepiece while adjusting the height of the photo tube. When the image is as clear as possible in both the focusing eyepiece and normal eyepieces lock down the photo tube locking ring and the set screw.

ZOOM STEREO MICROSCOPES

MEIJI TECHNO 

The image you wish to photograph should now be focused in all of the eyepieces and at the plane of the film.

The procedure is identical for the MA150/50, except you must use the viewfinder window located on your 35mm camera body to parfocal the camera attachment instead of using the focusing eyepiece. Viewing the image of the specimen using the MA150/50 camera attachment is more difficult due to the small size of the viewfinder window and the lack of 10X magnification that the MA150/60 focusing eyepiece adds.

CAMERA SETTINGS

The most difficult part of photomicrography is determining the proper film, aperture, and exposure for the images you wish to capture. There are so many factors that influence the way your pictures will turn out that it would be impossible to discuss them all here. Different cameras, different types of film, different specimens, different types of illumination, etc. will require different settings to achieve the desired photograph. The best advice is to experiment with your equipment to learn which settings work best. Shoot several pictures of the same specimen using different aperture and exposure settings, and keep a record of the settings for each frame so that when the film is developed you can get a feel for how changing the settings affects the photograph. Try different brands and speeds of film. Learn how your camera works. If you become serious about photomicrography, there are good books available from scientific supply companies that discuss these issues in more depth.

RZ Series

MEIJI TECHNO

LARGE FORMAT PHOTOMICROSCOPY EQUIPMENT

The MEIJI TECHNO **PMX100 Large Format Photographic Camera** mounts directly to the photo tube of the RZ Photo/Video attachment, featuring a built-in 10X magnification factor and comes equipped with a 10X widefield focusing eyepiece and framing reticle.

The following equipment is required for large format photography:

1. The MEIJI PMX100 Large Format Photomicrographic Camera
2. A Film Holder from the following sizes:

#405	3 1/4" x 4 1/4" pack film holder	#451	6cm x 9cm 8EX roll film holder
#545	4" x 5" sheet film holder	#453	6cm x 9cm 16EX roll film holder
#550	4" x 5" pack film holder	#432	6cm x 7cm 10EX roll film holder
3. Film to fit the above.

PMX100 COMPONENTS

- Film Holder Clips
- Connecting Frame
- Tripod Thread (on reverse side)
- Shutter
- Cable Release Socket
- Focusing Eyepiece with Framing Reticle
- Film Holder
- Dark Slide
- Camera Body
- Shutter Mount
- Lens and Beam-Splitter Prism Housing
- Mounting Sleeve
- Set Screw

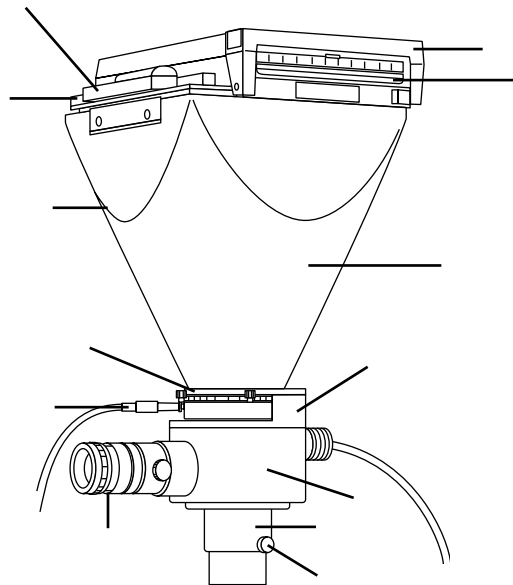

PMX100/405 Large Format Photographic Camera with #405 "Polaroid" Film Holder

ZOOM STEREO MICROSCOPES

MEIJI TECHNO 

PMX100 CAMERA OPERATION

- (1) Place the PMX100 photomicrographic camera over the photo tube. The PMX100 requires no photo eyepiece as the camera comes equipped with a 10X projection lens.
- (2) Install the film holder of your choice by loosening the clips and positioning the film holder on top of the connecting frame. After the film holder is properly positioned, tighten the film holder clips. Refer to the separate film holder instructions for film loading and use of the holder.
- (3) Focus the finder eyepiece on the image of the framing reticle installed in the viewfinder eyepiece. This is accomplished by rotating the knurled adjustment ring on the top portion of the focusing eyepiece while simultaneously viewing the image of the framing reticle.
- (4) Focus the microscope on the specimen using the coaxial coarse and fine focus controls.
- (5) Raise and lower the PMX100 camera on the photo tube while viewing the specimen through the focusing eyepiece. Lock the camera into position when the image is in sharp focus.

USING THE FRAMING RETICLE

The double crossline located in the center of the focusing eyepiece is used as a reference for critical focusing. When the double crosslines are clearly separated, the viewfinder is correctly focused. Four frames are visible in the field of view as illustrated below.

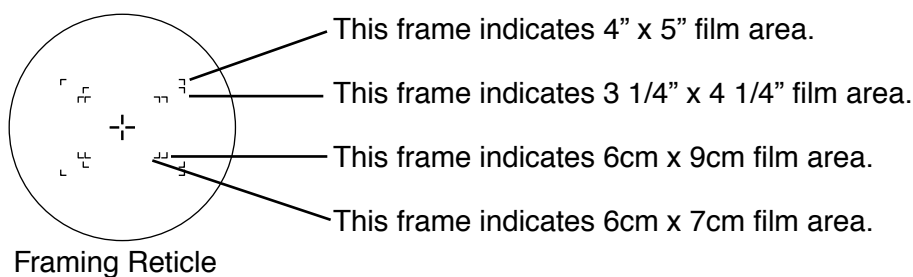

The area located outside of the frame is not photographed. When a larger area of the specimen is to be photographed, zoom the microscope to a lower magnification.

VIDEOMICROSCOPY EQUIPMENT

MEIJI TECHNO offers a variety of videomicrography equipment including cameras, monitors and "C" mounts in a range of magnifications.

1. VIDEO CAMERAS

CK3800N CCD color TV camera, 1/2" CCD, 450 lines horizontal resolution, NTSC system, 115V-DC12V adapter, BNC and Y/C cables.

CK3800P Same as above, except designed for the PAL (European) system, with DC adapter.

2. MONITORS

Information available upon request

3. "C" MOUNTS

"C" mounts have a standard 1" thread that fits most CCD cameras, and are used to connect the camera to the MA751 photo/video attachment or the MA752 auxiliary video attachment. The MA151/10 is a standard "C" mount with no projection lens (and thus no magnification factor) and comes included with the MA752. All other "C" mounts have projection lenses of various magnifications and must be ordered separately.

"C" Mounts with projection lenses for use with
MA751 Photo/Video Attachment

MA151/35/04 with 0.45X lens

MA151/35/15 with 1.0X lens

MA151/35/20 with 0.7X lens

MA151/35/25 with 2.5X lens

"C" Mounts with projection lenses for use with
MA752 Aux. Video Attachment

MA151/10 (included)

MA151/10/04 with 0.45X lens

MA151/10/15 with 1.0X lens

MA151/10/20 with 0.7X lens

MA151/10/25 with 2.5X lens

ZOOM STEREO MICROSCOPES

MEIJI TECHNO 

INSTALLING MA752 AUXILIARY VIDEO ATTACHMENT “C” MOUNTS

STANDARD “C” MOUNT

MA151/10 ASSEMBLY:

The MA151/10 consists of two parts: a 1” thread “C” mount portion with a set screw, and video tube that is already screwed into the video attachment. First loosen the set screw that holds the two parts together and remove the “C” mount portion. Next, remove the protective cover from the front of the CCD camera, and screw the “C” mount portion of the MA151/10 into the now-exposed threads on the CCD camera. Finally, slide the “C” mount/camera assembly over the video tube and tighten the set screw to secure the entire assembly.

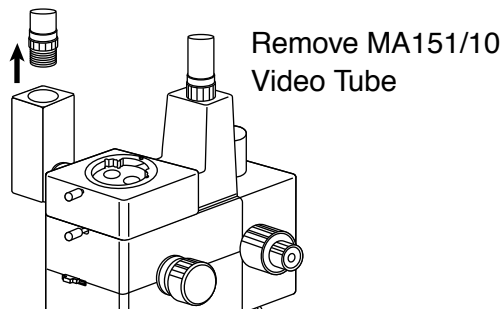
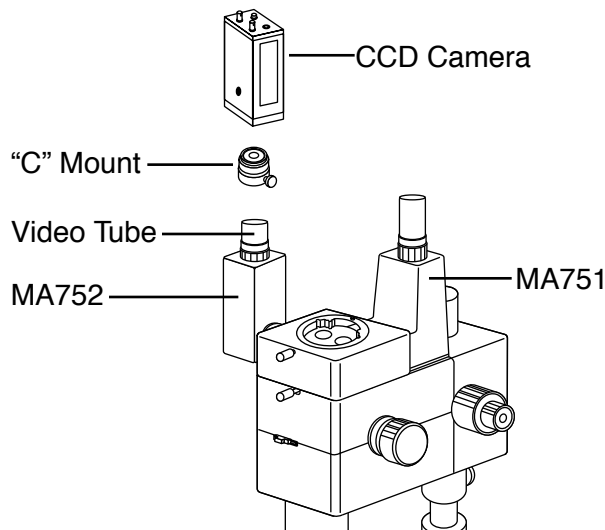

Remove MA151/10
Video Tube

“C” MOUNTS WITH PROJECTION LENSES

MA151/10/04, MA151/10/15, MA151/10/20, MA151/10/25

ASSEMBLY:

These are optional accessories and must be ordered separately. First, separate the silver “C” mount portion from the projection lens tube by loosening the set screw on the “C” mount. Then unscrew the video tube portion of the MA151/10 from the video attachment and replace it with the projection lens tube. Next remove the protective cover from the front of the CCD camera, and screw the “C” mount portion into the now exposed threads on the CCD camera. Finally, slide the “C” mount/camera assembly over the top of the projection lens tube and tighten the set screw on the “C” mount to secure the entire assembly.

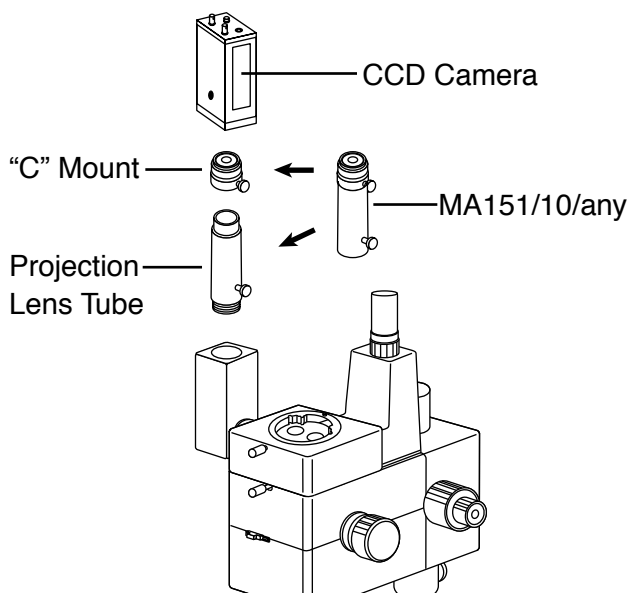

RZ Series

MEIJI TECHNO

INSTALLING MA751 PHOTO/VIDEO ATTACHMENT “C” MOUNTS

MA151/35/04, MA151/35/15, MA151/35/20,
MA151/35/25

ASSEMBLY:

These are optional accessories and must be ordered separately. First, separate the silver “C” mount portion from the projection lens tube by loosening the set screw on the “C” mount. Next remove the protective cover from the front of the CCD camera, and screw the “C” mount portion into the now exposed threads on the CCD camera. Then slide the projection lens tube over the photo tube. Finally, slide the “C” mount/camera assembly over the top of the projection lens tube and tighten the set screw on the “C” mount to secure the entire assembly.

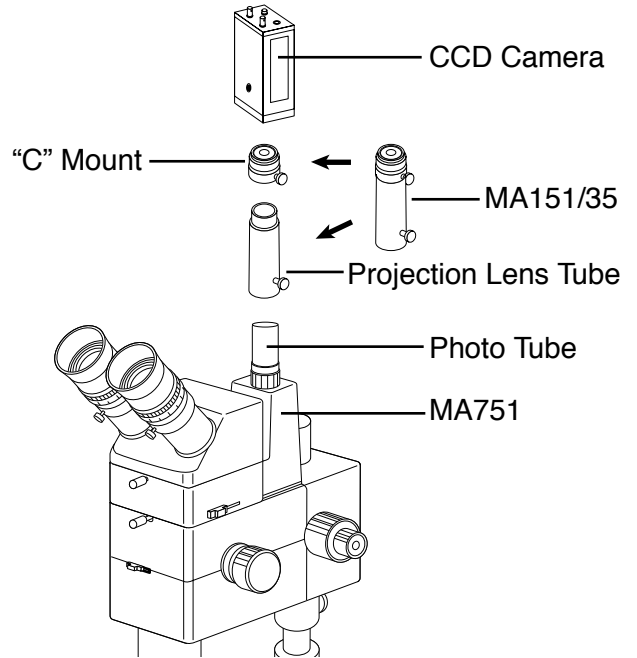

DRAWING ATTACHMENT

Although photographs and digital images are used for many applications where line drawings have formerly been used, skill in creating high quality line drawings of microscopic specimens will always be an asset. Not only are line drawings more economical to publish than photo or video images, they also allow the drawer to clearly render multiple layers of an object that cannot otherwise be brought into focus simultaneously. The MEIJI MA765 Drawing Attachment for the RZ Series gives you the power to create high quality detailed images of your most demanding specimens.

Cat. No. MA765

DETAILED INSTRUCTION MANUAL GOES WITH THE PRODUCT. SO, REFER TO THE MANUAL WHEN YOU HAVE IT IN HAND.

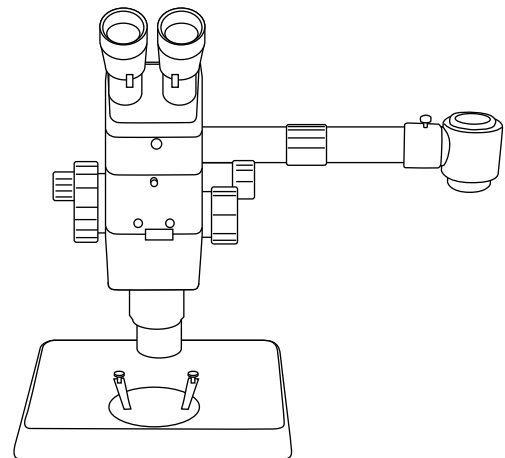

ZOOM STEREO MICROSCOPES

MEIJI TECHNO 

RZ Series MAGNIFICATION AND FIELD OF VIEW

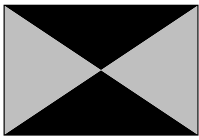
		PLANACHROMAT OBJECTIVES									
		1.0X		0.5X		0.75X		1.5X		2.0X	
		Working Distance		Working Distance		Working Distance		Working Distance		Working Distance	
Eyepiece Mag.	Zoom Indicator	78.5mm		164mm		107mm		43mm		29mm	
		Total Mag.	Field Diameter	Total Mag.	Field Diameter	Total Mag.	Field Diameter	Total Mag.	Field Diameter	Total Mag.	Field Diameter

UWF 10X Field No.24	0.75	7.5X	32	3.75X	64	5.62X	42.7	11.25X	21.3	15.0X	16
	1	10.0X	24	5.0X	48	7.5X	32	15.0X	16	20.0X	12
	1.5	15.0X	16	7.5X	32	11.25X	21.3	22.5X	10.7	30.0X	8
	2	20.0X	12	10.0X	24	15.0X	16	30.0X	8	40.0X	6
	2.5	25.0X	9.6	12.5X	19.2	18.75X	12.8	37.5X	6.4	50.0X	4.8
	3	30.0X	8	15.0X	16.0	22.5X	10.7	45.0X	5.3	60.0X	4
	3.5	35.0X	6.9	17.5X	13.7	26.25X	9.1	52.5X	4.6	70.0X	3.4
	4	40.0X	6	20.0X	12	30.0X	8	60.0X	4.0	80.0X	3
	5	50.0X	4.8	25.0X	9.6	37.5X	6.4	75.0X	3.2	100.0X	2.4
	6	60.0X	4	30.0X	8	45.0X	5.3	90.0X	2.7	120.0X	2
7	70.0X	3.4	35.0X	6.9	52.5X	4.6	105.0X	2.3	140.0X	1.7	
7.5	75.0X	3.2	37.5X	6.4	56.25X	4.3	112.5X	2.1	150.0X	1.6	

UWF 15X Field No.16	0.75	11.25X	21.3	5.62X	42.7	8.43X	28.4	16.87X	14.2	22.5X	10.7
	1	15.0X	16	7.5X	32	11.25X	21.3	22.5X	10.7	30.0X	8
	1.5	22.5X	10.7	11.25X	21.3	16.87X	14.2	33.75X	7.1	45.0X	5.3
	2	30.0X	8	15.0X	16	22.5X	10.7	45.0X	5.3	60.0X	4
	2.5	37.5X	6.4	18.75X	12.8	28.12X	8.5	56.25X	4.3	75.0X	3.2
	3	45.0X	5.3	22.5X	10.7	33.75X	7.1	67.5X	3.6	90.0X	2.7
	3.5	52.5X	4.6	26.2X	9.1	39.37X	6.1	78.75X	3	105.0X	2.3
	4	60.0X	4	30.0X	8	45.0X	5.3	90.0X	2.7	120.0X	2
	5	75.0X	3.2	37.5X	6.4	56.25X	4.3	112.5X	2.1	150.0X	1.6
	6	90.0X	2.7	45.0X	5.3	67.5X	3.6	135.0X	1.8	180.0X	1.3
7	105.0X	2.3	52.5X	4.6	78.7X	3	157.5X	1.5	210.0X	1.1	
7.5	112.5X	2.1	56.25X	4.3	84.37X	2.8	168.7X	1.4	225.0X	1	

UWF 20X Field No.12	0.75	15.0X	16	7.5X	32	11.25X	21.3	22.5X	10.7	30.0X	8
	1	20.0X	12	10.0X	24	15.0X	16	30.0X	8	40.0X	6
	1.5	30.0X	8	15.0X	16	22.5X	10.7	45.0X	5.3	60.0X	4
	2	40.0X	6	20.0X	12	30.0X	8	60.0X	4	80.0X	3
	2.5	50.0X	4.8	25.0X	9.6	37.5X	6.4	75.0X	3.2	100.0X	2.4
	3	60.0X	4	30.0X	8	45.0X	5.3	90.0X	2.7	120.0X	2
	3.5	70.0X	3.4	35.0X	6.9	52.5X	4.6	105.0X	2.3	140.0X	1.7
	4	80.0X	3	40.0X	6	60.0X	4	120.0X	2	160.0X	1.5
	5	100.0X	2.4	50.0X	4.8	75.0X	3.2	150.0X	1.6	200.0X	1.2
	6	120.0X	2	60.0X	4	90.0X	2.7	180.0X	1.3	240.0X	1
7	140.0X	1.7	70.0X	3.4	105.0X	2.3	210.0X	1.1	280.0X	0.9	
7.5	150.0X	1.6	75.0X	3.2	112.5X	2.1	225.0X	1	300.0X	0.8	

MAINTENANCE AND CARE

REPLACING THE BULB OR FUSE

Before replacing the bulb or fuse turn off the power to the microscope and disconnect the plug from the electrical power source.

After use, the bulb and lamp housing can become very hot! Take care not to touch the lamp housing and do not bring flammable substances (Alcohol, cleaning solvents, gasoline, paint thinner, etc.) near the lamp housing.

Never touch a new bulb with your bare hands! Oil deposits from your fingers can shorten the life of the bulb. If you have touched the surface of the bulb clean it with alcohol to remove residual oil.

Never handle hot bulbs! A hot bulb may explode if not handled correctly! Wait for the bulb to cool before installing a new bulb.

BULB REPLACEMENT RZT STANDS

The bulb on RZT stands is accessed through the bottom of the stand. It is best to remove the main body of the microscope and any accessory components before attempting to replace the bulb. Lay the stand on its back with the vertical mounting pillar parallel to the work surface. Remove the two screws securing the bulb door and gently pull the door away from the instrument. The bulb is held in the bulb socket which is attached to the bulb door. Be sure the bulb is cool to the touch and remove it by pulling it straight out of its socket. Do not twist the bulb as the two bulb pin legs may break off and become lodged in the socket. Handle the new bulb using tissue paper or the plastic wrapper and insert the two pin legs into the socket. Replace the bulb door and bulb door locking screws.

BULB REPLACEMENT FOR RZDT STANDS

The 50W bulb on RZDT stands is accessed through the external lamp house. After use, the bulb and external lamp housing can become very hot so proceed with extreme caution! Loosen the top clamp screw and twist the backing plate until the clamp screw clears the alignment slot and pull the backing plate, bulb socket and bulb away from the lamp house. Be sure the bulb is cool to the touch and remove it by pulling it straight out of its socket. Do not twist the bulb as the two bulb pin legs may break off and become lodged in the socket. Handle the new bulb using tissue paper or the plastic wrapper and insert the two pin legs into the socket. Replace the backing plate and secure the top clamp screw. Align the bulb using the lamp centering screw.

BULB REPLACEMENT FOR RZBD STANDS

The bulb on 150W models is accessed through the external fiber optic light source. The outer cover of the external light source (FL180A or FL180B) is hinged at the rear. Rotate the large locking screw found on the top/front of the cover counter clockwise and gently pull up on the handle. The cover will swing upwards and towards the rear exposing the bulb and bulb socket. The bulb and bulb reflector are removed as a unit. After use, the bulb and external lamp housing can become very hot so proceed with extreme caution! Slide the bulb vertically so the reflector unit and attached bulb socket clear the spring wires holding them in place. Disconnect the bulb and reflector unit from the bulb socket by gently pulling the unit away from the bulb socket. Do not twist the bulb as the two bulb pin legs may break off and become lodged in the socket. Handle the new bulb and reflector unit using tissue paper or the plastic wrapper and insert the two pin legs into the socket. Slide the bulb and reflector unit into its proper position in reverse sequence. Make certain that the spring wires firmly secure the bulb and reflector in place. Replace the cover and secure the locking screw by rotating it clockwise.

CARE

Always cover the microscope with the plastic dust cover that comes with the instrument when the microscope is not in use. Keep eyepieces in the eyetubes at all times to prevent dust from falling on the internal optics. Store the microscope in a clean environment free from moisture, mold, fungus or dust.

CLEANING

Lens surfaces may be cleaned using a soft brush, unsoiled, lint-free cloth, or a pressurized air canister. To remove finger prints and grease smudges moisten a lint free cleaning cloth with a small amount of absolute alcohol. Stubborn deposits may be removed with a small amount of Xylene. Never soak or immerse the optical components completely.

Avoid the use of any organic solvent on painted or rubber surfaces. Painted surfaces should be cleaned with a cloth moistened with water and a small amount of detergent.

DO NOT ATTEMPT TO MAKE ADJUSTMENTS TO THE INTERNAL OPTICS OR MECHANICS!

If the microscope does not seem to be functioning properly contact an authorized service or repair center.



www.MicroscopeWorld.com
800-942-0528 US Toll Free
760-438-0528 International
info@microscopeworld.com



MEIJI TECHNO CO.,LTD.

6, Oi-670, Oi-machi, Iruma-gun
Saitama 356-0053, Japan
Phone : 492-67-0911
Fax : 492-69-0691, 492-69-0692

MEIJI TECHNO AMERICA

2186 Bering Drive
San Jose, CA., 95131, USA
Phone : 408-428-9654 Fax : 408-428-0472
Toll free : 800-832-0060